

Product/Service Bulletin

Engine Block Heater Stand #EBH2

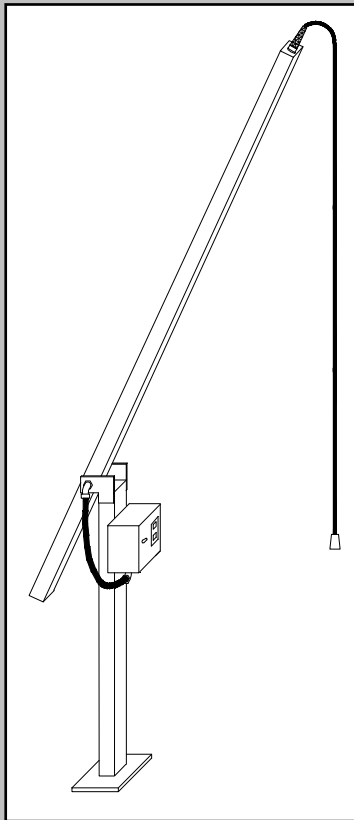

Direct Connect is
ISO 9001-2000
Registered



Direct Connect has developed the EBH2-Stand as an efficient, safe and cost effective way to run power to engine block heaters. The stand is designed to keep temporary power cords up and out of the elements while giving drivers safe and easy access.

FEATURES

- Counter-balanced boom arm keeps the cord off the ground and returns automatically to upright position.
- Waterproof construction.
- Pluggable portable cord for easy replacement.
- Powder coated aluminum to be corrosion resistant & lightweight
- Pre-wired with copper conductors.
- Pedestal pad mounted with swing arm construction.
- 20 Amp 120 Volt Rated
- On-Off switches, power-on lights and GFCI protection on each stand for operator and equipment protection.
- Designed to meet requirements of UL and the 2008 National Electrical Code
- Over 12 foot reach



**DIRECT CONNECT
SYSTEMS**

8246 Goldie Street
Commerce, MI 48390

Phone: 248-694-0130

Fax: 248-694-0138

sales@directconnectsystems.com

www.directconnectsystems.com

Direct Connect
SYSTEMS